

**data sheet – ceiling mounted turntables**

## Ceiling Mounted Turntables

Ceiling mounted displays and signage can transform a retail outlet, creating a dynamic, exciting and inviting environment that customers will be happy to visit over and over again.

Movetech UK's ceiling mounted units are not only superb at creating eye-catching displays but can also be used to draw attention to under-visited areas of a store, highlight special promotions, signpost important areas of the store such as a customer service desk, or raise the profile and visibility of higher value items.



Above all they save space on the sales floor or in the window, making maximum use of your display area.

With the optional slip ring facility on our mains powered turntables the display can be illuminated without winding up the wires, especially effective with chandeliers, which can be displayed lit as they rotate.

Add lighting, graphics, banners and other special effects – because used with flair and style, they will enhance any sales area to create a truly spectacular selling environment that will work for you day in day out.



All of our ceiling mounted turntables are supplied with a hook or eye bolt, thus fixing your display to our turntables could not be easier.

## Ceiling Mounted Battery Turntable

The battery unit is ideal for short-term promotion displays or where it is difficult to get mains power to the display location. Battery life can be up to 4 weeks.

The D-010-001 rotates at 2.5rpm and can carry a load up to 1kg in weight.

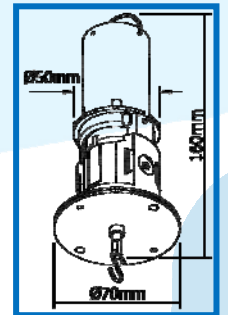

## Ceiling Mounted Mains Powered Turntables



These metal units offer a compact versatile solution for a smaller ceiling mounted display.

The range offers the option of either 5kg or 20kg capacity\* and the option of slip rings which provide power (5 amps) to the rotating display.

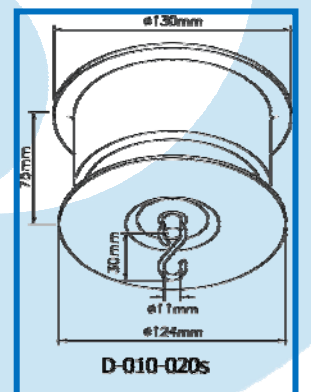

## Ceiling Mounted Heavy Duty Mains Powered Plastic Turntable

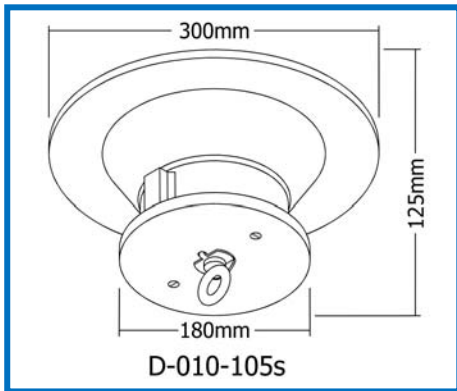

The 100 (D-010-100) and 105s (D-010-105s) units are extremely versatile, providing a cost-effective means of creating stylish, attention-grabbing displays and signs. Only 30cm in diameter, 12.5cm high and weighing only 3.6kg, they are easy to install and have the ability to carry an evenly distributed load up to 45kg in weight\*.

If you opt for the 105s version you will have slip ring capacity which provides power (5 amps) to the rotating display – making it even making it simple to create an extra-special effect.

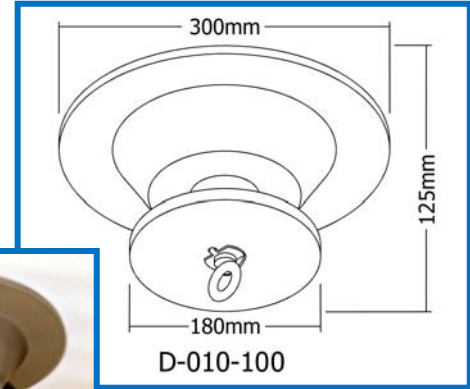

## Ceiling Mounted Heavy Duty Mains Powered Metal Turntables



With an impressive capacity of 227kg\*, the 505s (D-010-505s) is an incredibly powerful performer and the workhorse of many ceiling mounted displays. Weighing in at only 7.5kg, the 505s comes with a robust fixing flange for easy installation, 5amp slip rings to provide electrical power to the display, and a choice of forward and reverse rotation when designing or changing the display – a combination that enables suspended displays to act as the ultimate in attracting customers.

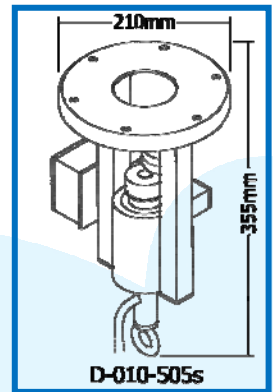

## Ceiling Mounted Turntable Range Summary Table

Product Code	Product Description	Slip Rings	Direction of Rotation	Speed (rpm)	Power Mode	Unit Dimensions			Max Display Properties		
						Diameter (mm)	Height (mm)	Weight (Kg)	Diameter (mm)	Height (mm)	Capacity kg*
D-010-001	Ceiling Mounted Turntable-001	No	Clockwise only	2.5	Battery - 1 x D Cell	50	185	0.25	500	500	1
D-010-005s	Ceiling Mounted Turntable-005s with slip rings	Yes	Clockwise only	2.5	Mains	125	72	3	1,000	1,000	5
D-010-005Z	Ceiling Mounted Turntable-005Z	No	Clockwise only	2.5	Mains	125	72	3	1,000	1,000	5
D-010-020	Ceiling Mounted Turntable-020	Yes	Clockwise only	2.5	Mains	125	72	3	600	900	20
D-010-020s	Ceiling Mounted Turntable-020s with slip rings	Yes	Clockwise only	2.5	Mains	125	72	3	600	900	20
D-010-100	Ceiling Mounted Turntable-100	No	Clock and Anti-Clockwise	2	Mains	300	125	3.6	1,200	1,000	45
D-010-105s	Ceiling Mounted Turntable-105s with slip rings	Yes	Clock and Anti-Clockwise	2	Mains	300	125	3.6	1,200	1,000	45
D-010-505s	Ceiling Mounted Turntable-505s with slip rings	Yes	Clock and Anti-Clockwise	2	Mains	210	355	7.5	1,500	1,200	227

\*Reliant on ceiling integrity and fixings used to secure turntable to ceiling